

SERIE - SERIES

GMA

**GRIGLIE A MAGLIA
QUADRA**

EGG CRATE GRILLES

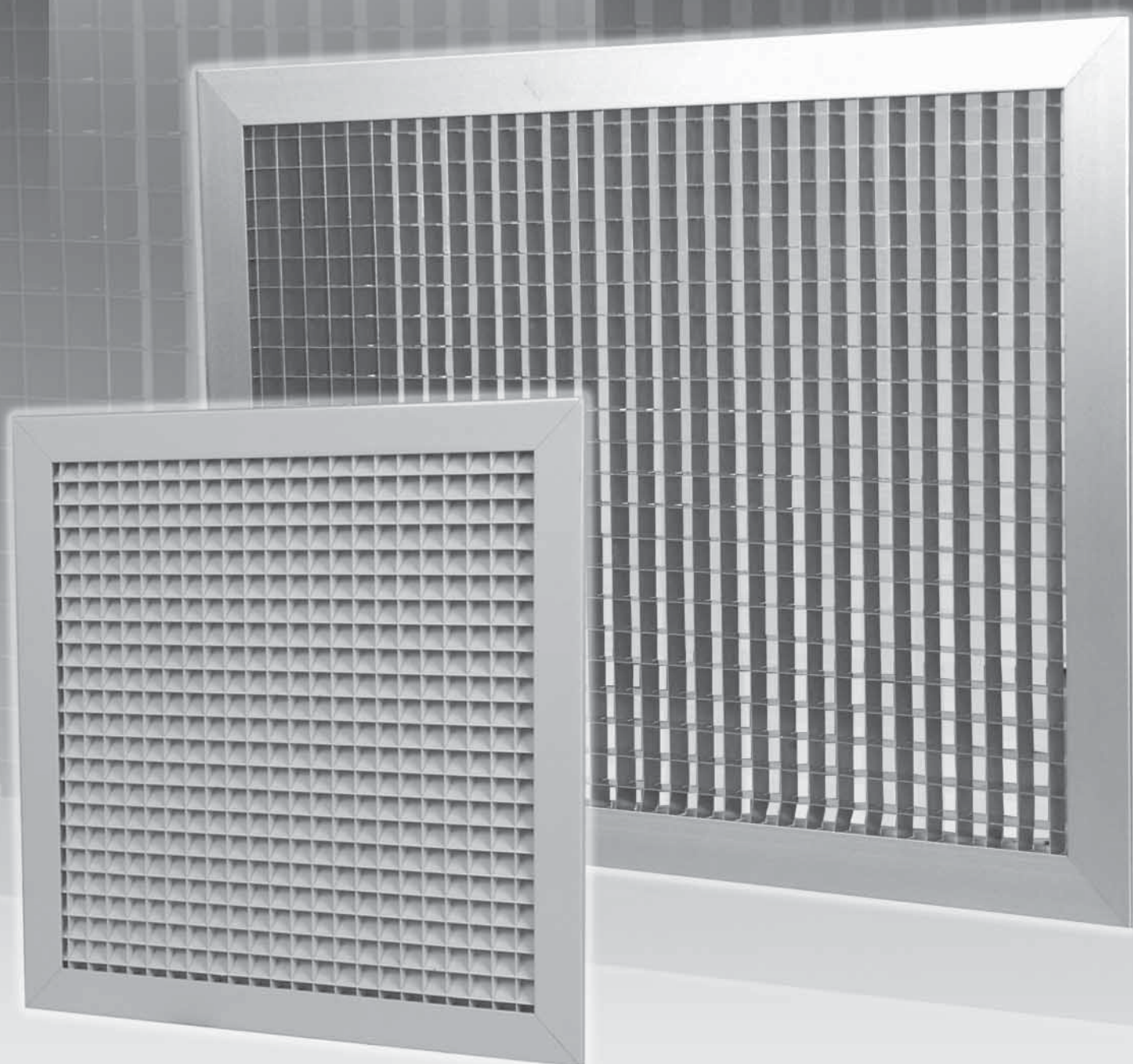

SERIE - SERIES

GMA

GRIGLIE A MAGLIA QUADRA

Le griglie a maglia quadra sono costituite da una cornice in alluminio e da una maglia quadra in alluminio 13x13mm.

Trovano la loro principale applicazione come prese d'aria, generalmente applicate su soffitti.

Hanno una superficie libera di passaggio dell'aria del 90%.

CARATTERISTICHE

Materiale: telaio in alluminio estruso,
parte centrale in grigliato di alluminio

Finitura: anodizzato al naturale / verniciato

EGG CRATE GRILLES

GMA series grilles are compound by an aluminium profile frame and an aluminium egg crate core 13 x 13 mm.

They are intended for use as air intakes in ceiling.

They have a large free area (90%).

CARACTERISTICS

Material: extruded aluminium frame
and aluminium egg crate core

Finish: natural anodised / painted

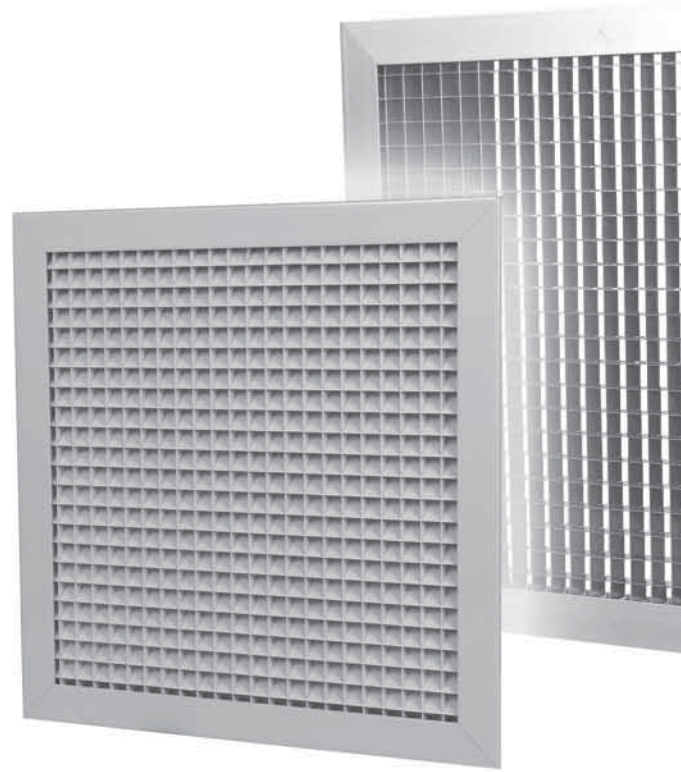

MODELLI

GMA: Griglia a maglia quadra

GMA 60: Griglia a maglia quadra 595 x 595 esterno cornice

GMA I : Griglia a maglia quadra inclinata 45°

MODELS

GMA: Egg crate grille

GMA 60: Egg crate grille 595 x 595 mm overall

GMA I : Egg crate grille 45° deflection (to reduce visibility through the grille)

DIMENSIONI D'INGOMBRO OVERALL DIMENSIONS

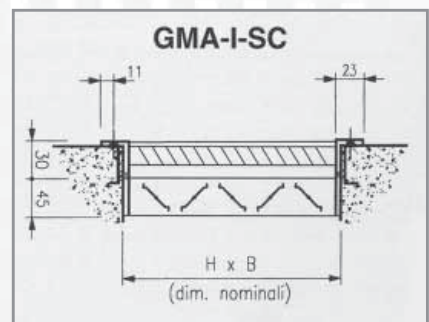
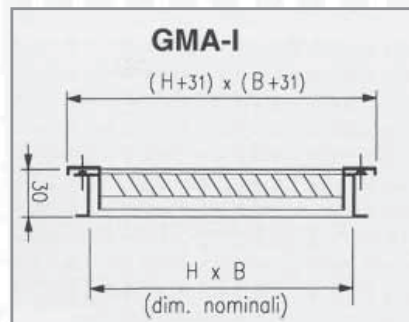
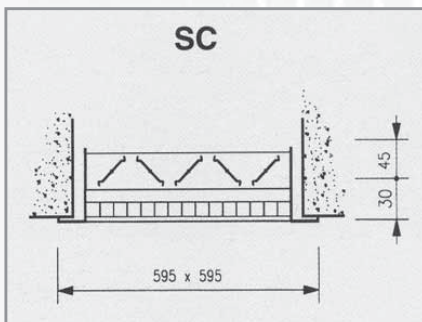
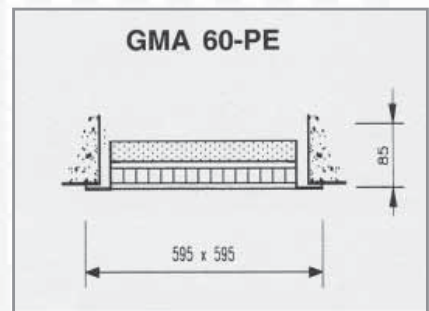
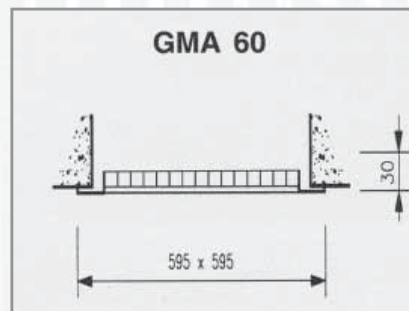
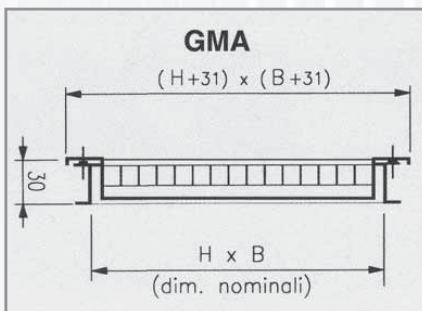

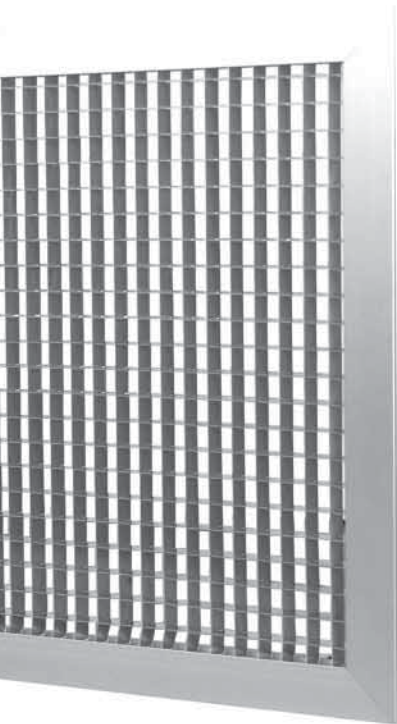

ACCESSORI

SC: serranda di taratura ad alette con movimento contrapposto

CT: Controtelaio di fissaggio in lamiera d'acciaio zincata.

PDZ: plenum di raccordo

Metodi di fissaggio

- fissaggio a viti frontali
- fissaggio a clips

ACCESSORIES

SC: *opposed blade damper*

CT: *counterframes in galvanised steel sheet profile section*

PDZ: *connecting plenum*

Fixing

- *Fixing by frontal screws*
- *Fixing by clips*

DIMENSIONI NOMINALI BxH (mm)

Sono disponibili tutte le combinazioni delle dimensioni BxH indicate nella tabella sotto riportata.

NOMINAL DIMENSIONS BxH (mm)

Are available in all b x h combinations as shown in the table below.

B	200	300	400	500	600	800
	1000	1200				
H	100	150	200	300	400	500
	600	800				

DIAGRAMMA DI SELEZIONE - DIAGRAM OF SELECTION

